

# MAXXI 35 ALTO

---

Model:  
MAXXI II - 35 -  
Nilfisk-ALTO

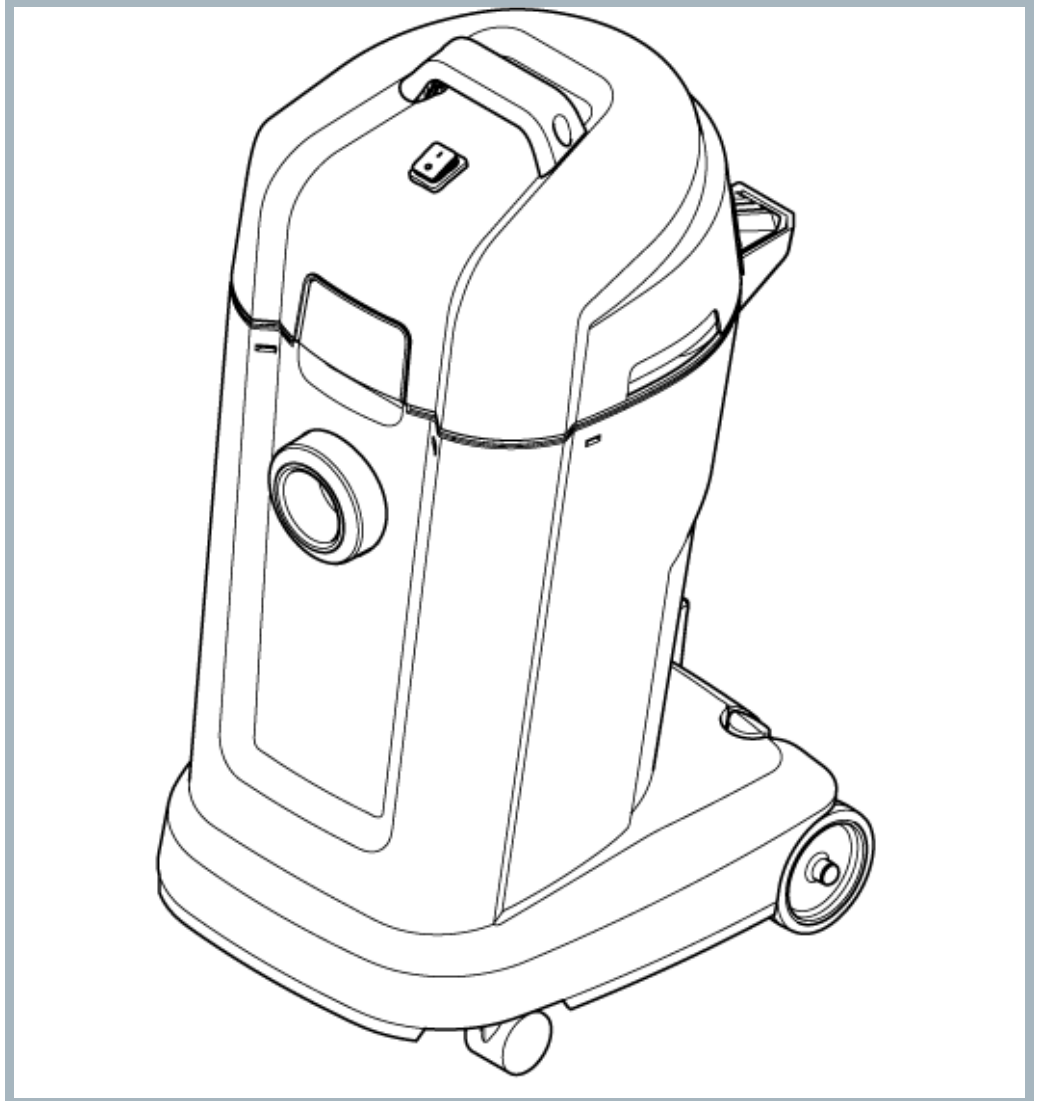

Liste de pièces Français

12-03-2015

# Table des matières

MAXXI 35 ALTO

<b>Top 35</b>	<b>3</b>
<b>Container 35 BSF, BDF, EDF</b>	<b>5</b>
<b>Filters and bags 35</b>	<b>7</b>
<b>Accessories 35</b>	<b>9</b>
<b>PIECES DETACHEES RECOMMANDEES</b>	<b>11</b>

# Top 35

MAXXI 35 ALTO

12-03-2015

ID Liste de pièces  
MAXXIII02

3

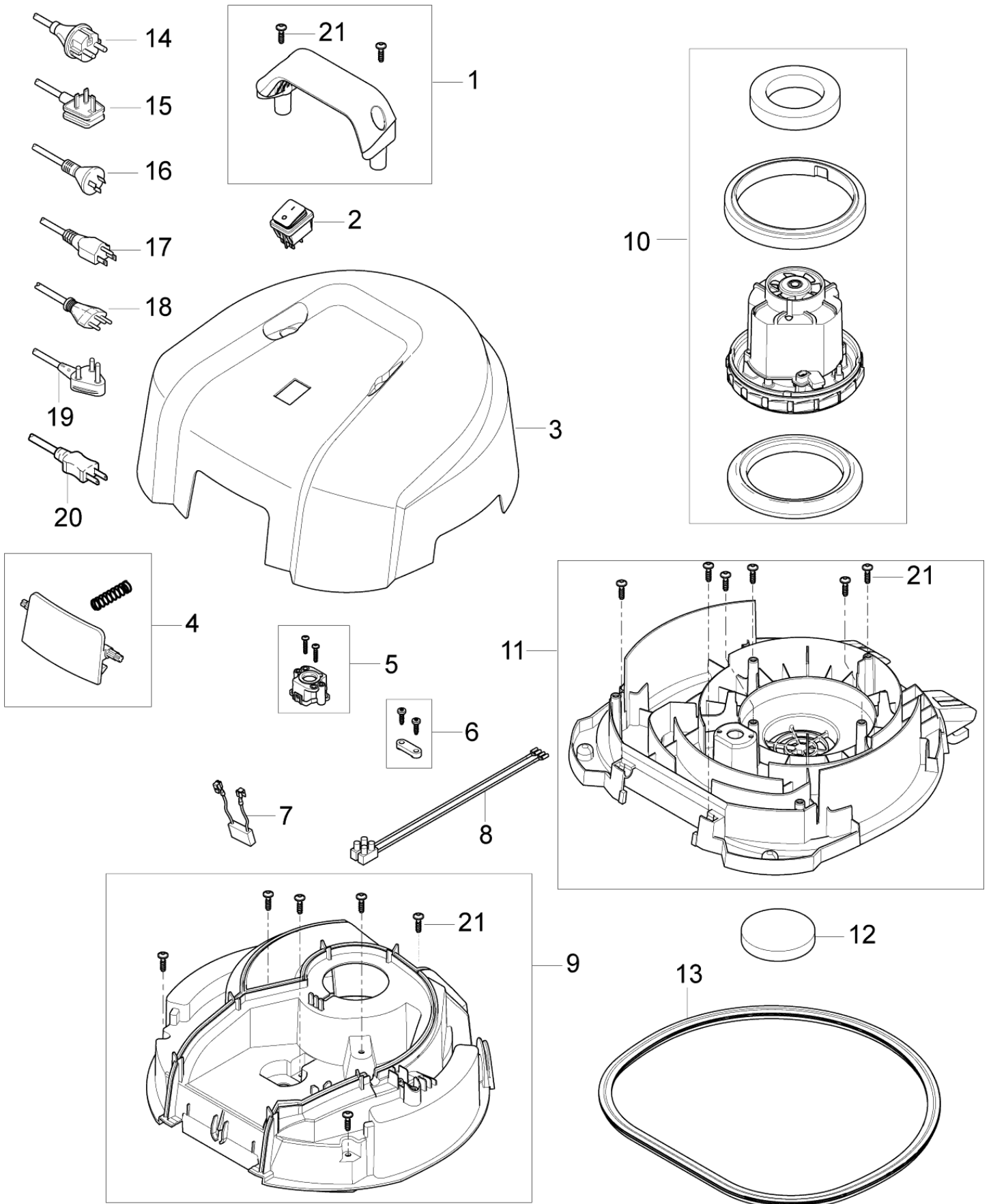

# Top 35

## MAXXI 35 ALTO

12-03-2015

ID Liste de pièces  
MAXXIII02

4

Pos	Réf. Pièce	Qté	Description	
0	107410810	1	PACKAGING VL500/MAXXI 35 - KIT	
01	107407234	1	POIGNEE NOIRE MAXXI II 35L	
02	107404540	1	INTERRUPTEUR	
03	107407306	1	CAPOT GRIS SUP TETE MONOMOTEUR MAXI 35L	
04	107407236	1	VERROUILLAGE TETE CUVE NOIRE MAXI II-75/	
05	107407237	1	SOUPAPE DE SECURITE CPL.	
06	140 6560 500	1	FIXATION DE CABLE+ VIS	
07	48338	1	CONDENSATEUR ANTIPARASITE	
08	140 7042 500	1	KIT CABLAGE INTERN	
09	107407238	1	CLAMPINGPLATE 35L	
10	107412971	1	MOTOR 1200W 100V 50/60HZ JP	
10	302003384	1	MOTEUR ÉLECTRIQUE 230/240 V	
10	302003388	1	MOTEUR ÉLECTRIQUE 120 V/60 HZ	
11	107407240	1	EMBASE SUPPORT MONOMOTEUR MAXXI II 35L	
12	140 8682 500	1	FILTRE MOTEUR	
13	107407241	1	JOINT PLAT DE CARTER 35L	
14	12222501	1	CABLE 10 METRES	
15	12222503	1	CORD SET UK L 10M	UK
16	12222506	1	CORD SET AU/NZ L 10M	
17	107401614	1	CORD SET US/TW 3C 15.5M YELLOW	
18	12222507	1	CORD SET CH L 10M	
19	107407242	1	POWER CORD H05VV-F 2X1.00 SABS 164-1 16A	
20	140 6702 500	1	CORD SET JP 15.5M	
21	302003704	8	VIS EJOT DELTA PT50X18WN5451	

# Container 35 BSF, BDF, EDF

MAXXI35 ALTO

12-03-2015

ID Liste de pièces  
MAXXIII08

5

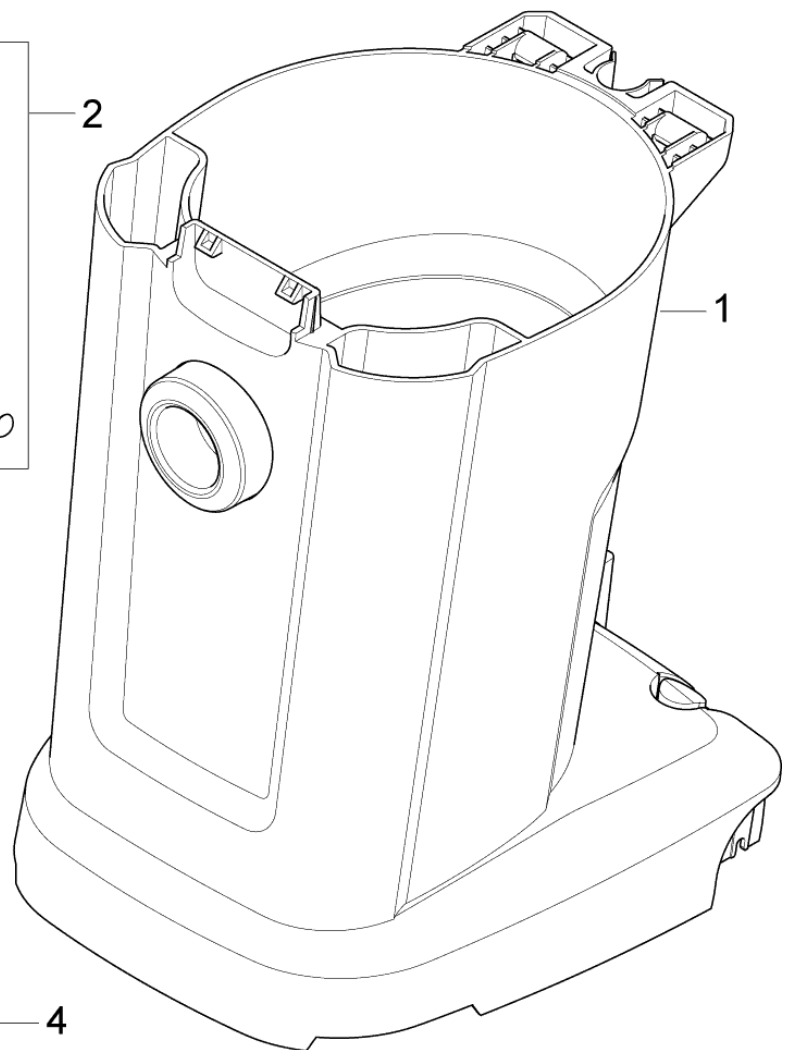
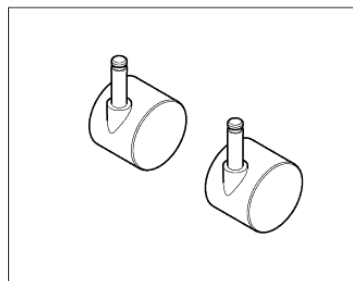
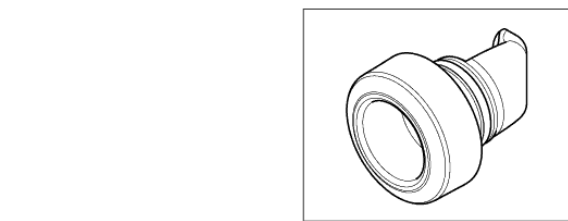
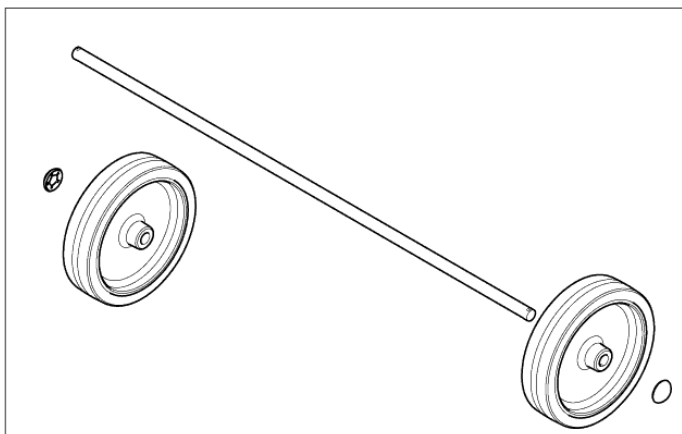

# Container 35 BSF, BDF, EDF

MAXXI 35 ALTO

12-03-2015

ID Liste de pièces  
MAXXI08

6

Pos	Réf. Pièce	Qté	Description
1	107407257	1	CUVE AVEC CHARIOT MAXXI 35L
2	140 8446 600	1	ROUES + AXE CENTRAL
3	107407259	1	ENTREE DE CUVEMAXXI
4	140 6422 500	1	ROULETTE

# Filters and bags 35

MAXXI35 ALTO

12-03-2015

ID Liste de pièces  
MAXXIII20

7

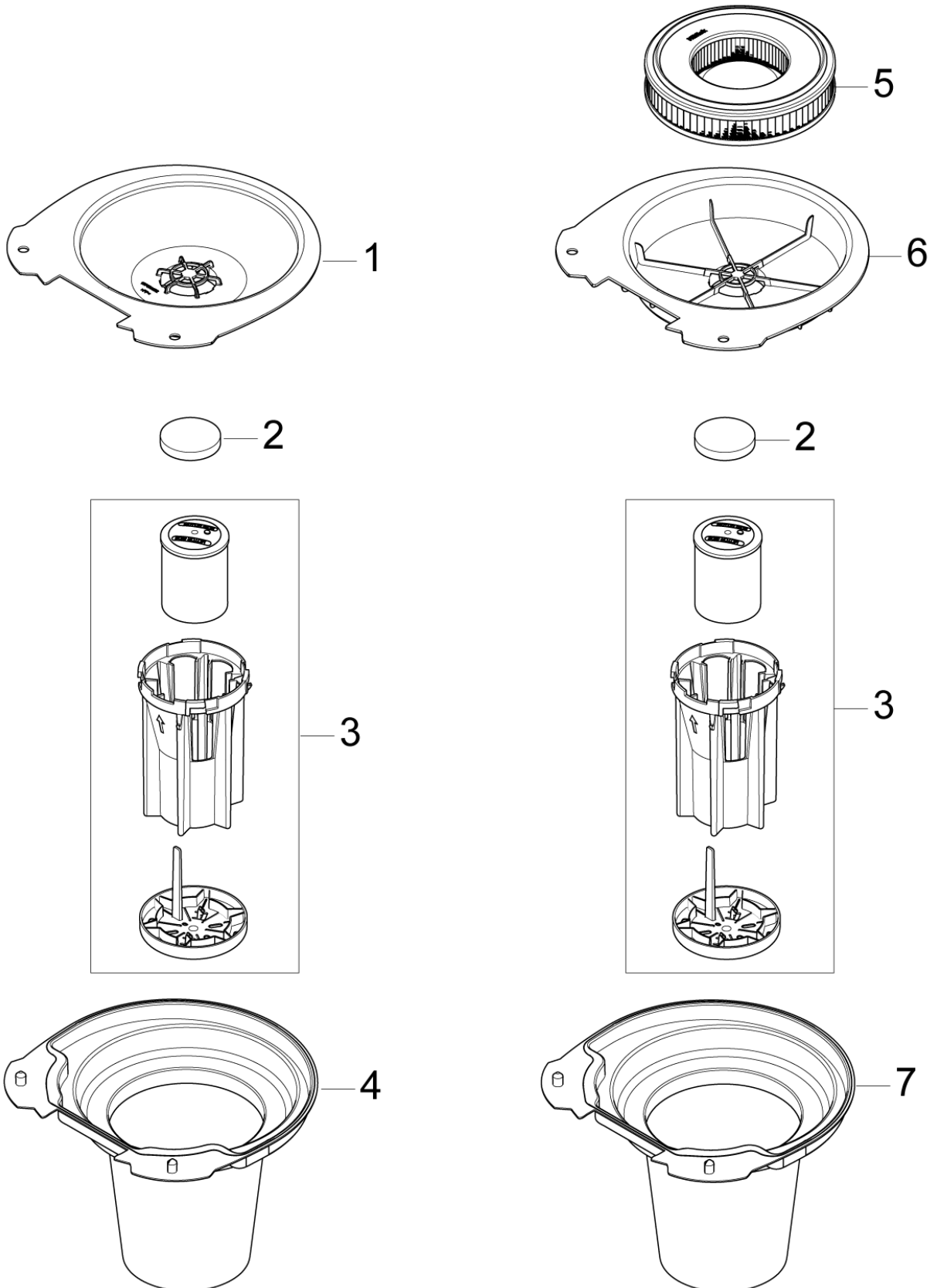

# Filters and bags 35

MAXXI 35 ALTO

12-03-2015

ID Liste de pièces  
MAXXIII20

8

Pos	Réf. Pièce	Qté	Description	
1	107407295	1	EMBASE CAGE FLOTTEUR 35L	BSF
2	140 8682 500	1	FILTRE MOTEUR	
3	140 8680 500	1	PANNIER + FLOTTEUR	
4	107407296	1	FILTRE PRINCIPAL POUSSIÈRE SUPPORT BLEU	BSF
5	107407297	1	CARTOUCHE FILTERANTE POUSSIÈRE 35L	BDF, EDF
6	107407298	1	SUPPORT DE FILTRE CUVE 35L	BSF, EDF
7	107407299	1	FILTRE A EAU 35L	BSF, EDF



# Accessories 35

MAXXI 35 ALTO

12-03-2015

ID Liste de pièces  
VL5003512

9

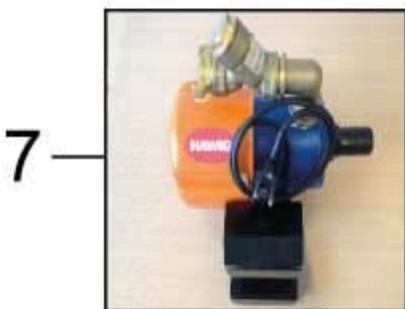

# Accessories 35

MAXXI 35 ALTO

12-03-2015

ID Liste de pièces  
VL5003512

10

Pos	Réf. Pièce	Qté	Description
1	302004004	1	LOT DE 5 SACS SYNTHETIQUE 40 L
2	107407308	1	FLEXIBLE CPLT D32 1.9M
3	107407310	1	EMBOUCHURE LIQUIDE D32(LAMELLES)
3	107407311	1	EMBOUCHURE POUSSIERE D32(BROSSES)
4	107407309	2	TUBE DROIT D32 - INOX
5	107407334	1	EMBOUT BISEAUTE D32
6	107407312	1	BROSSE RONDE D32
7	107408801	1	KIT POMPE A EAU AMOVIBLE 220-240V

# PIECES DETACHEES RECOMMANDEES

MAXXI35 ALTO

12-03-2015

ID Liste de pièces  
MAXXI35220

11

Pas de dessin pour la liste de pièces

# PIECES DETACHEES RECOMMANDEES

MAXXI 35 ALTO

12-03-2015

ID Liste de pièces  
MAXXI35Z20

12

Pos	Réf. Pièce	Qté	Description
	107404540	1	INTERRUPTEUR
	107407236	1	VERROUILLAGE TETE CUVE NOIRE MAXI II-75/
	107407237	1	SOUPAPE DE SECURITE CPL.
	107407259	1	ENTREE DE CUVEMAXXI
	107407295	1	EMBASE CAGE FLOTTEUR 35L
	107407296	1	FILTRE PRINCIPAL POUSSIERE SUPPORT BLEU
	107407297	1	CARTOUCHE FILTERANTE POUSSIERE 35L
	107407298	1	SUPPORT DE FILTRE CUVE 35L
	107407299	1	FILTRE A EAU 35L
	12222501	1	CABLE 10 METRES
	140 6422 500	1	ROULETTE
	140 8446 500	1	ROUES FIXES 2 UNIT'S
	140 8680 500	1	PANNIER + FLOTTEUR
	140 8682 500	1	FILTRE MOTEUR
	302003384	1	MOTEUR ÉLECTRIQUE 230/240 V
	302003388	1	MOTEUR ÉLECTRIQUE 120 V/60 HZ
	48338	1	CONDENSATEUR ANTIPARASITE